



We Put Kids First.

# Cargo Net

## PIONEER™ APPLICATION

### KIT INCLUDES:

QTY	DESCRIPTION
1	Cargo Net
8	Staples
2	Carriage Bolts
6	Loc Nuts
4	Bolt Covers
8	Beam Clamps
2	Wood Loc Washers
23	3" Screws
40	2" Screws
4	Flat Washers

### LUMBER REQUIRED (sold separately)

QTY	DESCRIPTION
1	4" x 4" x 8'

### INSTRUCTIONS

1. Cut 4" x 4" x 8' to 72". Align 4" x 4" base with right leg of deck assembly. Mark the center of the leg and base junctions and drill a 5/16" hole through both boards. Insert a carriage bolt through a wood loc washer and through each hole (on front side). Secure using a washer and loc nut (back side).
2. Drill four 5/16" holes in the top of the beam as indicated in Fig. 1. Attach beam clamps to the top and bottom of the beam over the holes and secure using 2" screws. Drill four 3/8" holes in the base as indicated in Fig. 1.
3. Remove existing carriage bolt from the bracket and replace with the first Cargo Net eye bolt. Insert remaining eye bolts through the beam and secure all of them using a beam clamp, washer and loc nut (see Fig. 2).
4. Place two rope staples as indicated in Fig. 3. Thread the Cargo Net through the holes of the base and loop through the staples as shown (Fig. 3). Pull tight and secure by pounding staples tight against the base.
5. Place bolt covers over the bolts as indicated in Fig. 2. Secure bolt covers using 2" screws.

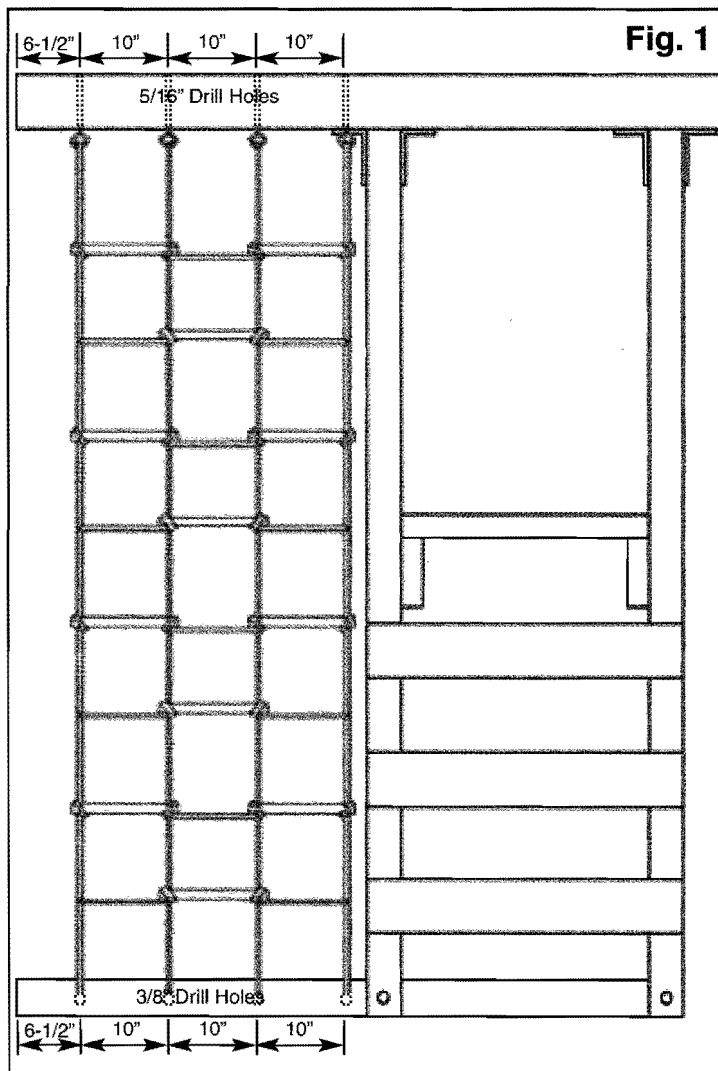

Fig. 1

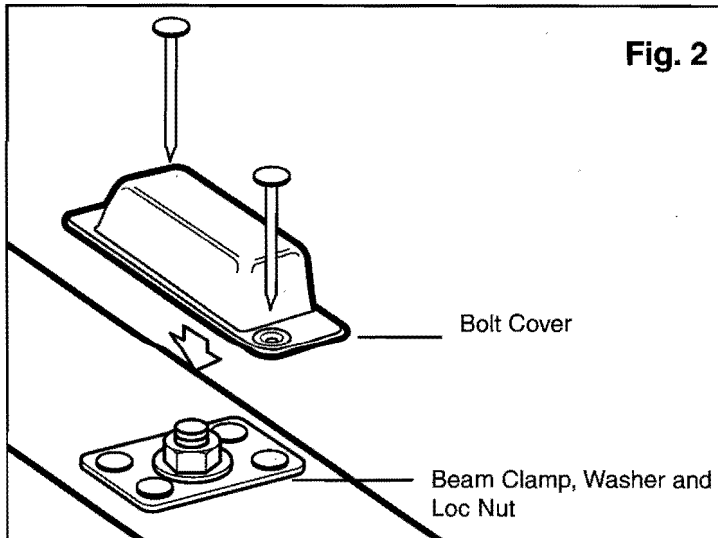

Fig. 2

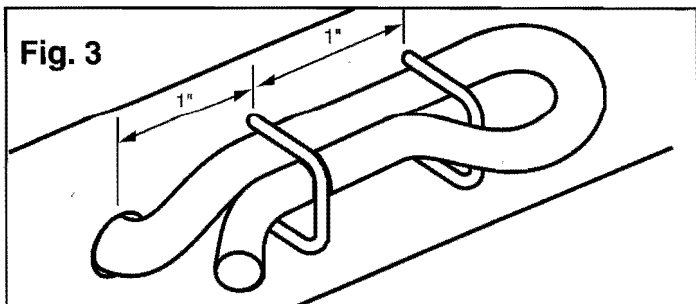

Fig. 3



We Put Kids First.

# Cargo Net

## STANDARD COMPETITOR™ APPLICATION

### KIT INCLUDES:

QTY	DESCRIPTION
1	Cargo Net
8	Staples
2	Carriage Bolts
6	Loc Nuts
4	Bolt Covers
8	Beam Clamps
2	Wood Loc Washers
23	3" Screws
40	2" Screws
4	Flat Washers

### LUMBER REQUIRED (sold separately)

QTY	DESCRIPTION
3	2" x 6" x 8'

### INSTRUCTIONS

1. Cut one 2" x 6" x 8' to 80". Cut one 2" x 6" x 8' to 40" and 43". Cut remaining 2" x 6" x 8' to 29".
  2. Remove the existing 2" x 6" x 60" base board from the unit. **NOTE:** Save the carriage bolts and associated hardware as they will be re-used.
  3. Attach the 2" x 6" x 80" board to the base as indicated in Fig. 1 using four 3" screws at each joint. Drill through the existing holes in the post and through the new base board. Insert previously removed carriage bolts and secure using hardware removed earlier.
  4. Attach remaining lumber to the unit as shown in Fig. 1 using three 3" screws per joint.
  5. Drill four 5/16" holes in the top board and four 3/8" holes in the bottom board as indicated in Fig. 2. **NOTE:** Drill through the bottom of the 2" x 4" board to the top. Insert the eye bolts of the Cargo Net through the holes of the top board and secure all of them using a beam clamp, washer and loc nut (see Fig. 3).
- NOTE:** Using a hacksaw, remove excess threads of the eyebolt as close to loc nut as possible.
6. Place bolt covers over the bolts as indicated in Fig. 3. Secure bolt covers using 2" screws.
  7. Place two rope staples as indicated in Fig. 4. Thread the Cargo Net through the holes of the base and loop through the staples as shown (Fig. 4). Pull tight and secure by pounding staples tight against the base.

